

# GSD

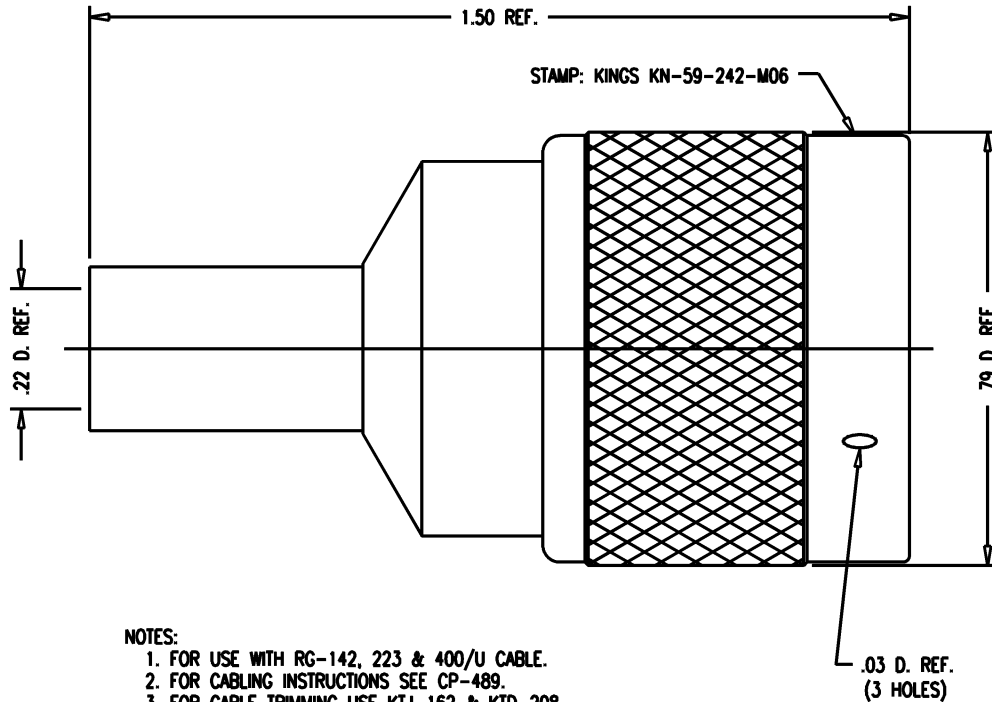

**NOTES:**

1. FOR USE WITH RG-142, 223 & 400/U CABLE.
2. FOR CABLING INSTRUCTIONS SEE CP-489.
3. FOR CABLE TRIMMING USE KTJ-162 & KTD-208.
4. FOR CRIMPING USE DIE KTH-2042.
5. INTERFACE PER MIL-STD-348, FIG. 304-1.
6. CENTER CONTACT SUPPLIED UNASSEMBLED.
7. MATERIALS:  
 INSULATOR: TEFLON, ASTM-D-1457  
 GASKET: SILICONE RUBBER, ZZ-R-765  
 OUTER CONTACT } PHOSPHOR BRONZE, QQ-B-750  
 C-RING }  
 ALL OTHER METAL PARTS: BRASS, ASTM-B16
8. FINISHES:  
 CONTACT: HARD GOLD PLATE PER MIL-G-45204  
 OUTER CONTACT: SILVER PLATE PER QQ-S-365  
 ALL OTHER METAL PARTS: KINGS TARNISH RESISTANT FINISH (TR-5)
9. ELECTRICAL CHARACTERISTICS:  
 NOMINAL IMPEDANCE: 50 OHMS  
 WORKING VOLTAGE: 1000 VRMS  
 FREQUENCY RANGE: DC TO 11 GHz

KN-59-242-M06

**REVISIONS**

ISSUE	CHANGES
4	CN 34063 C REDRAWN JCA 09/10/92

JCA3104

SCALE 4:1
APPROX SURFACE AREA
USED ON
REF:
PLUG, N
DRAWN JCA DATE 09/10/92
DESIGN LI DATE 09/11/92
APPR. DATE

**KINGS**  
ELECTRONICS CO., INC.  
TUCKAHOE, NEW YORK 10707

KN-59-242-M06

# GSD